

REV.	DESCRIPTION	DATE	APPROVED
1	Green Light Pallet-Corrugated Feeder	12/13/09	
2	Design Review	2/23/2009	

KEPES
Mailing and Finishing Solutions

PROPRIETARY AND CONFIDENTIAL <small>THE INFORMATION CONTAINED IN THIS DRAWING IS THE SOLE PROPERTY OF KEPES INC. ANY REPRODUCTION IN PART OR AS A WHOLE WITHOUT THE WRITTEN PERMISSION OF KEPES INC IS PROHIBITED.</small>	SIZE A	DATE 01/13/09	REV 2
	Description Corrugated Feeder-Design Review 022309		SHEET 1 OF 2

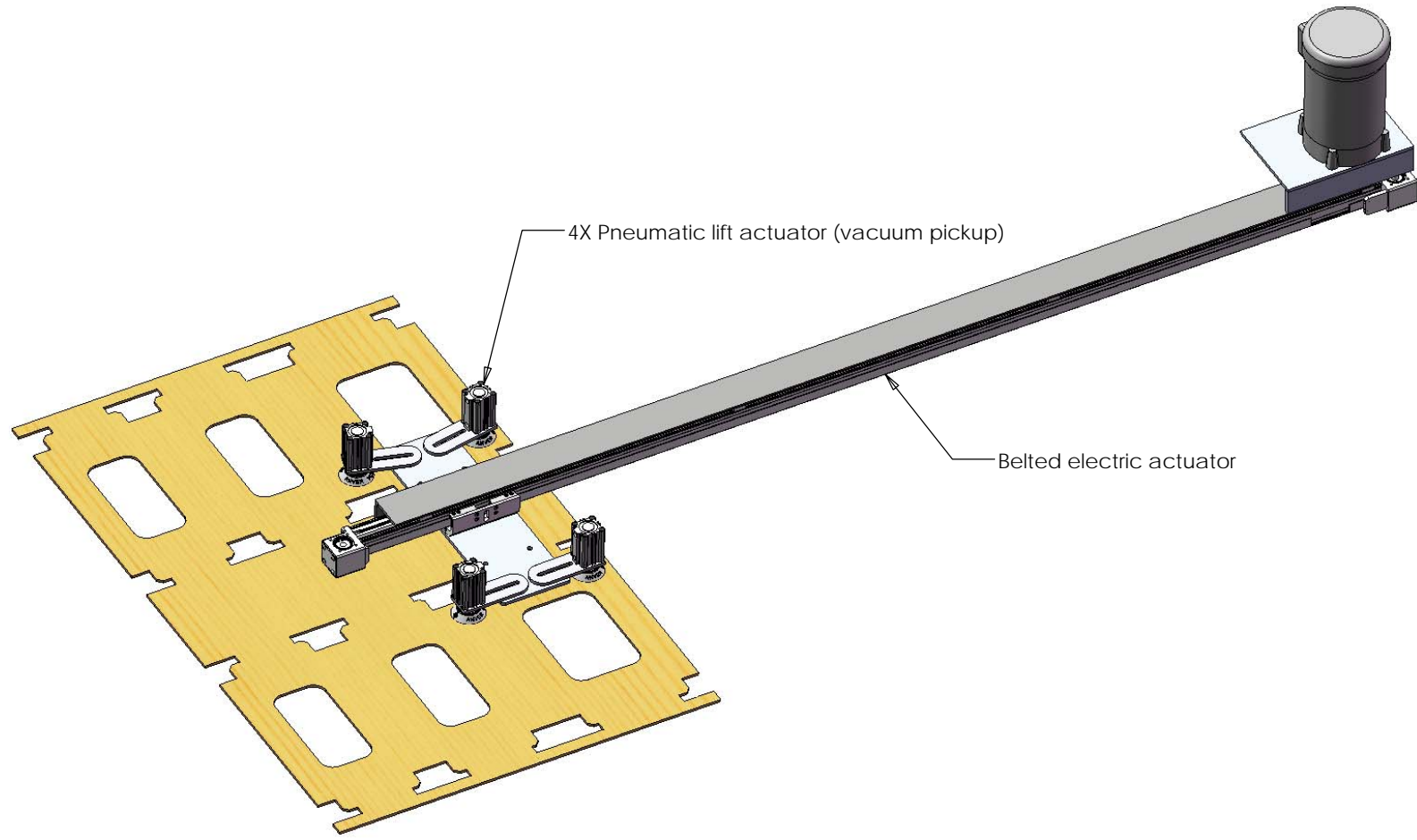

4X Pneumatic lift actuator (vacuum pickup)

Belted electric actuator



PROPRIETARY AND CONFIDENTIAL <small>THE INFORMATION CONTAINED IN THIS DRAWING IS THE SOLE PROPERTY OF KEPES INC. ANY REPRODUCTION IN PART OR AS A WHOLE WITHOUT THE WRITTEN PERMISSION OF KEPES INC IS PROHIBITED.</small>	SIZE A	DATE 01/13/09	REV 2
	Description Corrugated Feeder-Design Review 022309		SHEET 2 OF 2